

The 2003-2005 Jaguar XK8 Convertible

Some content for this article has been borrowed from various internet sources, some with attribution and some without. The 2003-2006MY-XK8 WorkshopManual.pdf covers vehicles from **VIN A30645 to A48684**, and the CD is available from JagDocs.com. If you are fortunate enough to own one of these fine cars, you should get accurate electrical diagrams for your model year, acquaint yourself with all TSBs, assess whether they apply to your particular vehicle and participate in Jaguar Forum discussions. Many routine maintenance items are relatively easy DIY tasks. Others require specialized knowledge, proprietary tools and/or a lift. My particular 2005MY XK8 is a North American model (Left Hand Drive). Many design changes were made as the model matured. Jaguar documentation and aftermarket listings may contain errors regarding which parts are installed on which model year vehicles, requiring extra vigilance when sourcing replacement parts.

By Gary R VanRemortel vanremog@aol.com

Revision E dated 09/06/14



Engine Type: AJ34 4.2L (4196cc [256 CID]) DOHC aluminum alloy 32-valve 90° V8

Avg Fuel Economy: 21 mpg

Bore/Stroke: 86mm / 90.3mm

Warm Idle: 650 rpm

Max Power/Torque: 294 hp SAE @ 6000 rpm / 303 lb-ft SAE @ 4100 rpm

BMEP: 12.35 Bar (181.5 psig) Max, 10 Bar (147 psig) at 1500 rpm

Wheelbase/Width/Track/Length/Height: 101.9" / 70.8" / 59" / 188" / 51"

Minimum Turning Radius: 18.1 ft

Max Speed (ignition limited): 155 mph

Acceleration (0 to 60 mph): 6.3 sec

Curb/Gross Weight: 3980 lb / 4808 lb

Coefficient of Drag: 0.36

Spark Plugs/Gap/Socket Size/Torque: NGK IFR5N-10 Iridium / .047" / 5/8" / 20 lb-ft

Coolant/DI Water 50/50: ~10 qt WSS M97B44-D -34 to 265°F (Dexcool OAT Red/Orange)

Fuel Capacity/Type/Rail Pressure: 19.9 gal / 91 octane unleaded gasoline / MAP+56 psi

Oil Circulation Volume @ Max Pressure: ~10 gpm @ 68 psig

Differential Fluid: 2 qt 75W-90 Redline Synthetic

Power Steering and Soft Top Hydraulic Fluid: Pentosin CHF11S

Brakes Front/Rear: 325 X 28mm vented slotted and drilled disc / 305 X 20mm vented disc

Brake Fluid: Ate DOT4

Battery: AC Delco 49PS 90Ah

Alternator: W0133-1956598 150A w/S6 Pulley

Wheels Front/Rear: Keystone ALY59794U85 (19" X 8") / ALY59795U85 (19" X 9") Chrome Atlas

Tires Front/Rear: P245/40ZR19 (32 psig) / P255/40ZR19 (34psig)

Lug Nut Bolt Circle/Thread/Torque: 5 Lugs on 4.75" [120.65mm] centers / ½"-20 / 65-75 lb-ft

Overview

XK8 enthusiasts describe the car as having poise, grace and refined power. The stretched bonnet, boot proportions and large oval grille evoke familiar classic features of the legendary XKE. It has a look that is both muscular and voluptuous, due to its length, large wheels and convex panels. Eye-shaped lighting fixtures enhance its distinctive cat-like aura. The original side rub strips are gone, leaving a clean, smooth look, so be sure to park yours well away from potential door bangers.

The Jaguar XK8 is all car; however, it is not a race-ready sports car as was the XKE. In contrast to the aggressive masculine character of the Chevrolet Corvette, the XK8 exudes a powerful feline beauty, offers opulent sport luxury appointments and surrounds the occupants with rich wood and leather refinements. It is arguably one of the most esthetically pleasing automobiles in the world. It is not just basic transportation, but it can be a superb daily driver. I strongly encourage XK8 owners to take a personal interest in learning about their car's systems, care about their ongoing condition and see to their periodic needs. I don't usually flush the power-steering and brake systems, preferring instead to suck the old fluids out of their respective reservoirs and refill with new fluid yearly. I use the RC hobby equivalent of a turkey baster (Sullivan Products Glow Fuel Bulb) with a 6" length of silicone RC fuel line on the tip to get out as much of the old fluid as possible. Remember to keep all automotive tools and chemicals locked up or out of the reach of children and pets.

Several weaknesses in the original design have been addressed in the AJ34 4.2L engine XK8s, but there are additional items of which you should be made aware, so following are my opinions/observations on the car's systems. If you think an important issue has been overlooked or an error made in this article, or just to discuss various XK8 issues, please contact me directly.

Be aware that repair shops may have policies against installing non-Jaguar branded replacement parts, so you may be in a DIY situation if you wish to install aftermarket parts. Professional Maintenance Technicians are not Engineers, are not equipped to render a judgment on the quality of your alien parts and they don't want you suing them if something goes wrong with your car as a result. You should respect this mindset. Also be aware that the systems on the XK8 are tucked into every little nook and cranny of the car and access is often extremely difficult. This is why Jag Techs can make good money. Therefore you can save big money if you do much of the routine maintenance yourself.

High-strength steel members throughout the car assure a rigid body structure, while crumple zones at the front and rear corners are designed to absorb forces in a crash. There are triangulation braces running from the top of the firewall to the strut towers and convertibles have additional cross-bracing under the engine bay, stiffening members in the door sills and a reinforced windshield frame, helping to compensate for the lack of a roof structure and significantly reducing scuttle shake. The XK8 body is entirely new, but the floor-pan is modified from the XJS. The body-in-white is both stiffer and lighter than the XJS. Torsional stiffness is improved by 25% and the body structure consists of 30% fewer panels. Special high-strength steels form the panels subject to the highest loads (approximately 15% of the body), including the front longitudinals, seat-belt anchors, suspension mounting points, bumper mounts and the side-impact beams within each door.

Cabriolet owners will certainly experience all the pleasures of top-down motoring--with the convenience of one-button operation and automatic latching--yet they will also be treated to cabin refinement on a par with many luxury coupes. The quiet, draft-free interior is the result of several factors: a world-class sealing system, a fully lined and padded soft top, 5mm thick heated rear glass and a painstaking attention to detail by design house Karmann of Germany, who shared in the body development work.

Engine

The Jaguar designed AJ34 closed deck (no valley pan, just a plug) naturally aspirated V8 engine has 5 main bearings and is compact, lightweight (441 lb) and strong running all the way to its 6400 rpm redline. The thrust bearing is in the center. Unlike its famous V12 predecessor however, its torque curve rolls off noticeably below 2000 rpm, but this tradeoff returns good mileage at legal freeway speeds. As shown in the line drawing below, the bedplate mates to the cylinder block and the bottom structural oil sump mates to the bedplate, providing exceptional rigidity, durability and refinement. In the Cosworth designed pentroof cylinder heads, variable intake cam phasing (VVT) provides responsiveness with good fuel economy across a wide range of driving conditions. The Krebsoge sinter-forged steel connecting rods are fracture-split at the crank end.

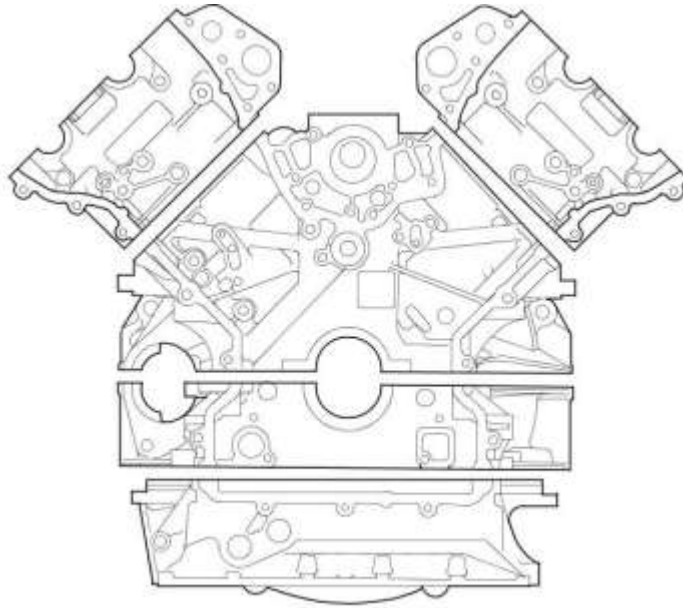

EP1285

The original Jaguar AJ26 4.0L non-VVT engines were class leaders in weight, stiffness, low friction, high power output and efficiency. The AJV8 series engines were updated periodically to improve performance, emissions and economy, to the point that the very few things that do tend to go wrong in the newer AJ34 engines are relatively easy DIY endeavors. Attention to these concerns will ensure that you get good service from this fine engine. The 4.0L engines suffered from eroding Nikasil cylinder plating (due to the high sulfur allowed in fuel at the time, combined with excess moisture brought on by short trips) but this was dealt with early on. The AJ34 engines all have iron bores and an output graph is shown below. BSFC is a very efficient 0.40 lb/hp/hr.

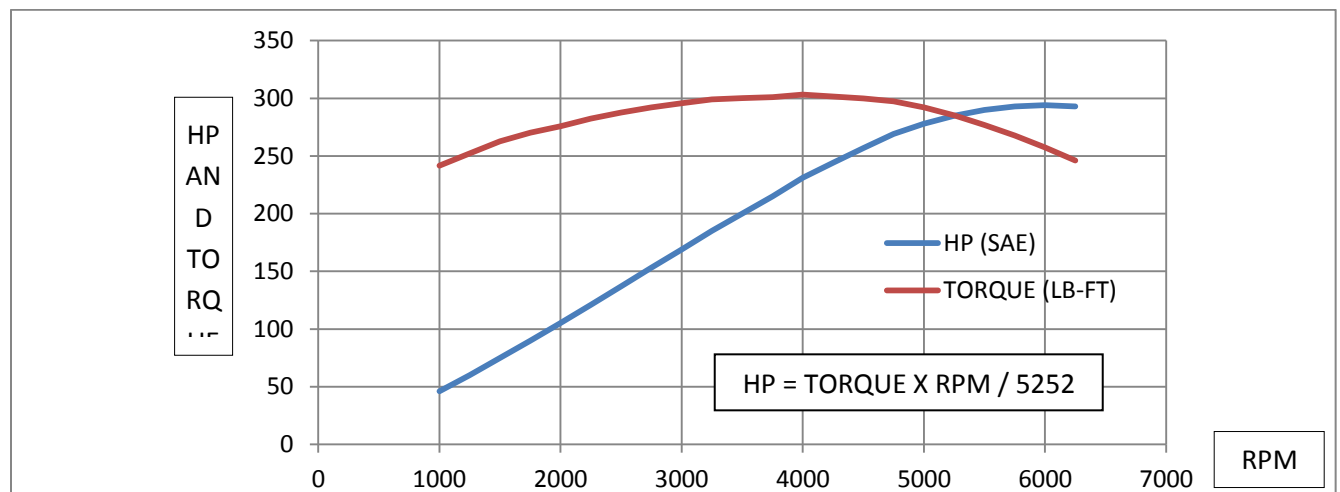



Valvetrain

The AJ34 4.2L engine introduced in the XK8 2003MY uses tougher Morse chains (rather than the simplex chains used in the 4.0L engines) and has aluminum-bodied (rather than the original plastic) cam chain tensioners. These more robust components better handle the torsional load reversals that occur in the intake cams of the VVT-equipped naturally aspirated engines. The now wider Variable Valve Timing (VVT) rotates the cam up to 48° within 0.7 sec. The supercharged engines don't have VVT, so they are easier on the chains and tensioners. Gun-drilled camshafts, shimmed-for-life inverted bucket lifters and light (5mm dia) valve stems reduce the valve train mass and cam loads as much as possible. The intake and exhaust valve axes are 28° apart, forming near ideal combustion chamber geometry for this 11:1 compression ratio engine, and valve lift is 9mm. Jaguar specifies the use of Premium (91 RON) unleaded fuel.



Ignition

Ignition is via a world-class NipponDenso 32-Bit electronic management system. Individual coil packs sit atop each spark plug, retained by a single bolt. As of the 2002MY, Bank 1 (passenger side) cylinder designations front to back are 1, 3, 5 and 7, Bank 2 are designated 2, 4, 6 and 8. Firing order is 1-2-7-3-4-5-6-8. Spark plugs in this high energy system should be replaced every 50K mi and robust electrode types should be used. Get a good magnetic socket, as the plugs are quite deep in their wells. Changing plugs is an easy DIY job, taking about 30 minutes. Any oil found within the plug wells is either leaking from the valve cover seals or the plugs were not properly torqued.

Lubrication

These engines require 8 qt of the finest Synthetic 5W-30 or 10W-30 oil you can get your hands on. I use Pennzoil Ultra but the Euro 5W-40 stuff is also great. Just now becoming widely available, the new Pennzoil Ultra Platinum with PurePlus™ Technology is likely one of the best oils you can currently buy. Establish regular oil/filter service at 5K or 7.5K mi intervals, any other practice of more extended service intervals being false economy, and please recycle your old oil. I recommend Mahle OC602 and Mann W719/7 oil filters (both ~\$15 from Rock Auto). I feel that the cheapest oil filters having common paper media are virtually useless at trapping the combustion by-products (mostly carbon) that get into the oil. The synthetic media provides better filtration. An oil change is an easy DIY job, taking about 30 minutes. Cast-iron sleeves allow a bit more oil loss than do Nikasil lined bores. I installed the Fumoto F-106 (M14-1.5 thread w/o nipple) oil drain valve to make my oil changes easier. Never let the oil level get low -- if the low oil light comes ON, it may be too late.



Cooling System

The engine has a split flow, low volume, high flow cooling system allowing the engine to reach operating temperature very quickly (<4 minutes), contributing to ready drivability, low emissions and good fuel economy. In my opinion Jaguar really should have incorporated a more substantial thermal blanket with a high R factor instead of the light aluminum heat shields separating the back of the engine, catalyts and center muffler from the cabin. The waste heat from the engine makes the cabin cozy in the winter, but makes use of the A/C mandatory with the top up in ambient temperatures above 80°F.

The coolant used is modern Organic Acid Technology (OAT) ethylene glycol (Dexcool colored Red/Orange meeting WSS M97B44-D) and it is **incompatible** with many other non-OAT mixtures (they can combine to form an insoluble gel). The additive package depletes slowly over heat cycles, so change coolant every 50K mi or 3 yrs, whichever comes first. Pressure testing the cooling system at the same time is always a good idea. Pressure flushing and flow checking should be done at 100K mi with a new radiator due somewhere between 100K and 150K mi. The plastic coolant expansion tank W0133-1657480 is a robust part but the puny magnetic float level sender is pretty much toast by 75K mi. I bought the whole thing with cap and sender for around \$140 and it appears that the float sender is super-glued in place. This expansion tank has two side nipples angled forward, the rear being a closed off artifact of the earlier engines.

The original 4.0L coolant pumps had Black Nylon 6/6 impellers that degraded in short order, leading to overheated engines. Impellers were changed first to black PolyPhenylene Sulfide (PPS) and then finally to white PPS. All of the AJ34 engines got the improved pumps, but plastic impellers have been known to spin on their shafts. Aluminum impeller equipped equivalent pumps W0133-1609249 (also Bosch 96181) are readily available. Allegations that the aluminum impellers cavitate more than do the plastic ones cannot be confirmed. These pumps are well made, last for ~100K mi, should be supplied with a metal composite gasket and changing one is an easy DIY job, taking about an hour. Three tabs in the gasket center fold up into the corresponding recesses around the outside of the pump throat. Unfortunately the gaskets aren't as good as the pumps. Visually check for coolant seepage at

the weep hole on the underside of the housing halfway between the rear bearing and the front bearing. Check for gasket failure, evident by a greasy looking dirt buildup on the engine block right under the pump (because boiled out glycol becomes sticky). A vestigial O-ring between the gasket and the engine block shown in some of the literature is no longer needed, but doesn't hurt. Proper torque on the pump attachment bolts is critical to a good installation. Change the serpentine belt and the thermostat at the same time as the pump. For some reason Jaguar recommends replacing the three pump pulley bolts (item 5 in the drawing below), when they are really not stressed much in this installation (the center boss carries the entire side load). Then they add insult to injury by pricing them outrageously. I reused them.

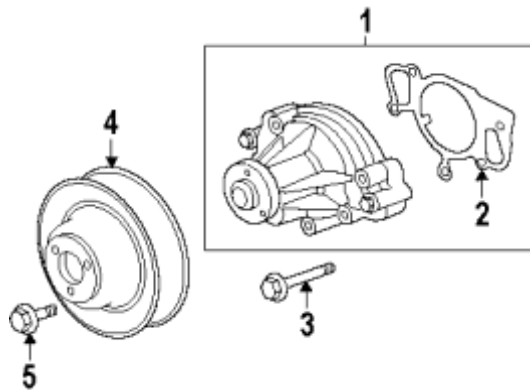

The correct thermostat for the naturally aspirated AJ34 is W0133-1655931 or AJ82697. It is quite different than that used on the 4.0L engines, as is the plastic plumbing tower assembly in which it mounts. There is an aluminum version of the thermostat cover-housing AJ89484 in the aftermarket supply chain, the thermostat mounting method being the same. There is also a blocked-off lower nipple on this housing that suggests that it is an artifact of another version. The plastic parts are superior to the earlier phenolic parts used on the 4.0L engines, but because they are still plastic, they should be inspected closely to ensure they are in good condition for continued use. The installation of the four-piece thermostat is a little confusing for the first timer and some have installed them backwards. The correct arrangement is shown below in the left photo and its installation is best done wearing gloves. The right facing pin fits into a hole in the housing, then install the springs in/on the cap. Then compress the cap bracket against the springs until the two bent tangs can be rotated into their retention slots in the housing. There is no jiggle pin in this thermostat, so its rotational orientation in the housing is not an issue. There is a robust black elastomeric perimeter seal AJ83525 in a slot in the thermostat tower assembly that should be replaced as long as you have the thermostat housing off. Thermostat replacement is an easy DIY job, taking about 30 minutes.



The coolant level should never be allowed to get low in the expansion tank, and if the low coolant light ever comes ON, it's likely too late. The use of a 15 psi valve expansion tank cap MJA4440BA at the very top of the system combined with an atmospheric recovery tank is a great setup, because

whatever blows out of the expansion tank cap valve during hot operation theoretically gets returned to the system. Make sure that the system is really doing its job by keeping the atmospheric recovery tank at least ¼ full of coolant, otherwise the tubing “straw” can unport (suck wind) and fail to return coolant to the pressurized portion of the system as it cools. It is difficult to assess the state of fill in the atmospheric recovery tank, as it is out of sight, out of mind and inaccessible for easy filling in the rear of the right front wheelwell.

The OEM coolant hoses going to the radiator C2N1173 (bottom) and C2N1174 (top) flow well, but are relatively thin wall, making them prone to heat softening, cut-thru and blow off/out. The inexpensive OEM “constant tension” spring steel hose clamps used are fast to install (with the right tool), compact and allow for expansion/contraction of the plastic hose nipples and compression set of the rubber hoses during heat cycles. But IMO they are “one time use” items. They should be replaced well before reaching 100K mi, along with the hoses they retain. You can get new ones from most good auto parts outlets and McMaster-Carr. For most 1” ID and smaller cooling applications calling for straight or gently curving hose, I prefer fiber reinforced silicone hose often used on Police cars. I have used HPS, Verocious and Silicone Intakes hose firewall forward with good results on both cars and airplanes.

There is a hard plastic burp line running from a right angle nipple atop the thermostat tower assy to the most forward side nipple on the expansion tank. It is captured in between the plastic engine cover and the intake manifold, so it sees substantial heat. I’ve had similar items overheat and shatter on BMWs, so mine is now a length of 5/16” [8mm] ID reinforced silicone hose from Z1 Motorsports.

The radiator is actually three separate heat-exchanger cores. A thin A/C radiator core sits in front of the main radiator. The main radiator is divided into a coolant portion and a transmission fluid portion. At the bottom and in front of these radiators is yet a fourth heat-exchanger for cooling the power steering fluid. The coolant drain-plug JLM20622 (Dorman 61138 is identical for about half the Jag price) is located at the bottom of the right radiator end cap facing aft and is a bit fiddly, having a hard pipe partially in the way, preventing a straight shot at tightening it with your screwdriver. It has a rubber seal under the head and barbs on the end to retain it in the port when unscrewed. It is molded black polyethylene with M10-1.5 threads, so be careful not to over tighten it or you may develop slow seepage that might not show up on the ground.

There are two rather fiddly square head bolts retaining the top of the fan assy against the radiator. With their hex nuts removed, they are free to pop out, drop down into the structures below and/or get lost. It would be wise to wedge some foam or double-stick tape in between their heads and the molded radiator slots to keep them in place when removing and reinstalling the fan assembly.

Serpentine Belt

The naturally aspirated AJ34 engine uses a single six rib 91” serpentine belt, Dayco 6PK2310 or equivalent and it generally lasts for somewhere between 50K and 75K mi (or about 5 yrs). The tension on the belt is released using a 3/8” square drive breaker bar with a short piece of pipe to extend the handle. There isn’t much room between the tensioner recess and the left side fan hub. The belt tensioner (T) and idler pulley (G) bearings are probably good for 150K mi or more. Replacement is an easy DIY job taking about 30 minutes. I keep a few Ethafoam blocks around to hold the belt in place on pulleys #1, #4 and #7 until I can get it around the tensioner #2.

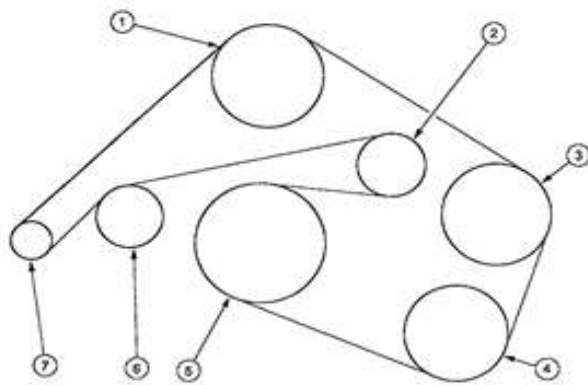

1. Water Pump Pulley
2. Belt Tensioner
3. Power Steering Pump Pulley
4. A/C Compressor Pulley
5. Crankshaft Pulley
6. Idler Pulley
7. Generator Pulley

000277190

Naturally Aspirated Induction/Intake System

The induction system in the XK8 begins with a scoop in the right front fender feeding directly into the filter box, thru a short coupler that incorporates the MAF sensor mount, then into a 21" long plastic induction pipe W0133-1657567, having a 4" bellows section and two right angle turns on the way to the rear mounted throttle body. There isn't much clearance in the engine bay so, as the bonnet liner/insulator blanket sags in its mounting clips over time, it can brush lightly against the crests of the bellows section of the induction pipe if it's not fully seated. There is a small amount of relative motion between the bonnet liner and the induction pipe. It doesn't actually move very much, but it does so thousands of times per minute and the liner, being quite abrasive, slowly sands its way thru the crests of the plastic bellows. You should watch for this.



Reusable filters like the K&N 33-2190 are available to replace disposable paper elements and there are several aftermarket Cold Air Intake kits that may prove to be slight improvements over the OEM design. If your air filter is working well, you will only need to clean your MAF sensor every 100K mi or so using only a commercial MAF sensor cleaning solvent. The MAF sensor can be unplugged and removed from the intake pipe for easy cleaning access.

Return-less Fuel System

The fuel tank sits between the rear seat back and the boot. Beginning with the 2003MY, a return-less fuel system was introduced. A new plastic jacketed vane pump C2N1146 with integral float sender and particulate filter sock sits in the tank. All submerged fuel pumps rely on the fuel in the tank for effective cooling, so don't make a habit of running the tank near empty. Conversely do not overfill the tank or you may foul the vapor canister system. The advantages claimed for return-less systems are primarily lower vapor loss, as hot fuel in the injector rail is not returned to the tank, fuel line routing is simpler, there are fewer opportunities for leaks and the reduction in circulated volume means a somewhat extended fuel filter life. The Fuel Pump Module (FPM) is able to run the pump at higher pressures (nominally ~56 psi above manifold air pressure) compared to the previous return type system, so theoretically it can better fight vapor lock. Any time you shut down a highly heat soaked engine and start it up again before it has had sufficient time to cool, vapor could have already formed in the rail. Winter blend or fuels of poor quality may increase this tendency. All of the heat that used to get carried into the fuel tank in a return-line system, now tries to boil the light ends of trapped fuel in the rail at startup. I wish Jaguar would have done a better job of isolating the fuel rail from the hot engine block. All fuel systems have advantages and disadvantages, so just be advised of this particular system's characteristics. If you get a lazy fuel injector, your engine may start, but idle poorly until the fuel flow stabilizes. A scan tool may show DTCs P0301 thru P0308, and the second time it happens, you might get a Check Engine Light (MIL) and DTC P0316. It probably also means it's time to send the injectors out for cleaning and flow balancing.

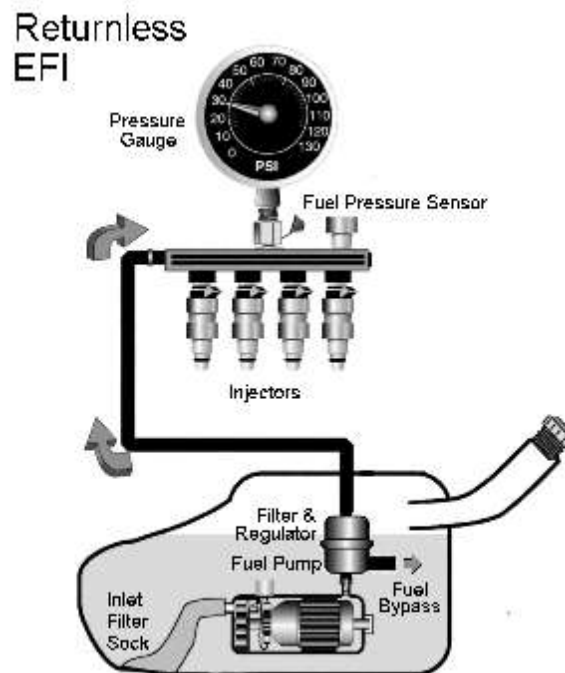

The FPM gets its commands from the Engine Control Module (ECM). There is no longer a fuel pump relay. When the ignition key is ON, 12VDC is supplied via Fuse #5 in the boot fuse box thru the FPM to the pump. During engine operation, the ECM polls the requisite pressure and temperature sensors in the engine compartment to get snapshots of how things are going and commands the FPM to modulate the ground circuit of the fuel pump (between 5 and 50%) to maintain the appropriate fuel rail pressure under these conditions. When things go wrong, even in this simple feedback network, it can be difficult to determine precisely which component is actually at fault without specialized diagnostic equipment. It's like a series string of Christmas lights. It could be a sensor, the FPM, an injector, a filter or the pump.

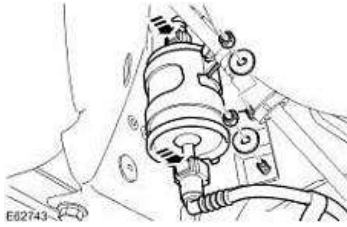

The inline fuel filter, located in the left rear wheelwell above and ahead of the axle, should be replaced every 50K mi. This filter has changed substantially for the 2003-2005MY XK8s, although many parts suppliers haven't gotten the word. The Jaguar OEM fuel filter is C2S20977 or W0133-1657566 (\$80) and my filter had P/N 1X439155AA and "Made in Poland" stamped on it. That P/N cross references to Mahle KL83 and Mann WK512/1, (both ~\$20 from Amazon). Instead of the threaded o-ring sealed ports of the pre-2003MY XK8 filters, the new filters have 5/16" [8mm] dia straight tubes with raised circumferential ridges halfway down to capture the radial clips in the Norma-Quick disconnect fittings on the fuel lines. You'll need a special plastic tool like the Lisle 39410. I have had difficulty getting aluminum tools (like Performance Tool W83152) to properly release these fittings without a struggle. Maybe it's because the plastic tools are more slippery, but you still need to drive them firmly and deeply into the fittings to get them to release.

Before you start, Pull Fuse #5 in the boot fuse box and try to start the car to reduce fuel line pressure. It helps immensely if you get the back end of the car up on jack stands and remove the left rear wheel. There is just enough room to maneuver in this tight area. You will need to use both hands and come in from a variety of directions to get the little buggger out. You will need a couple of 4 inch long 1/4" square drive extensions snapped together to reach the 10mm headed nut holding the filter bracket to the underbody before releasing the Norma-Quick fittings. The fuel system will not siphon out of the tank with the filter disconnected, as long as the pump is not powered up. Some fuel in the lines will blast out, but the volume is actually quite small. Once you have the filter and bracket out, you can loosen the smaller 8mm headed nut and transfer the bracket over to the new filter. The flow direction is shown on the filter can and the rimmed end of the filter faces down (forward). Any supplementary plastic barbed fittings provided with the new fuel filter may be discarded. All in all it's about a 30 minute job with reassembly being the reverse of disassembly.

In the engine bay, near the fuel line fitting to the fuel rail, there is an inline Pulse Damper (a little nickel plated steel device with a spring loaded diaphragm inside). It's not a regulator, usually causes no problems and its job is merely to smooth out pressure variations (pulses) in the system. The fuel rail itself is pretty straightforward and consists of two cross connected pipes, the right pipe having a front mounting flange for the fuel pressure sensor and a threaded back end for the fuel temperature sensor. There is a common Schrader valve on the left side pipe next to the fuel supply line fitting. Keep in mind that your OBD2 scanner sees fuel rail pressure relative to MAP. Unlike the 4.0L engines, the fuel rail on the AJ34 engine is separate from the intake manifold. Unhook the fuel supply line safety clip and then use a 1/2" fuel line tool (310-D005 or equivalent) to release the quick-disconnect fitting. There are two O-rings, so you will need to pull hard until the fitting releases. Disconnect the vacuum line and connectors on the sensors and remove the entire rail with the injectors still attached. On the bench remove each clip and injector from the fuel rail one at a time. Mark them with cylinder numbers for reference.



The Denso (not Bosch) fuel injectors AJ82363 (orange) in the AJ34 engines have improving targeting and 12 teeny tiny orifices that need to be kept fastidiously clean. These 20.1 lb/hr @ 3 bar injectors are Ford P/N 2W93-AA, use the EV6 (Black w/red insert) type connector and are the high impedance (13 Ohm) type. Fuel injector cleaning solvents that are used in the fuel tank may help, but they won't keep these particular injectors free from muck build-up over the long haul. Injector orifices and pintles accumulate varnish and the valving action can become sluggish. These injectors have very fine mesh inlet basket filters to catch debris that escapes the inline fuel filter. Filters can supposedly be removed by chucking a sheet metal screw in a vise, screwing the injector over it and gently rocking it back and forth to extract, but this didn't work for me. Mine were clean after back flushing, so I just left them in. If you need new inlet filters, MrInjectorUK has them. There are a number of DIY on-car solvent flushing systems (OTC 7448 and others) available for between \$120 and \$220, or you can build your own for less than half that. Off-car cleaning is much more effective than forward flushing of the fuel rail and injectors in situ, since you can then clean/replace the screens, back-flush, verify the spray pattern and confirm flow matching on an individual basis. Flush the rail with Berryman's B-12 while you have it off.

If you suspect that you are having individual injector firing issues, a Noid light (Lisle 27800) or current limited LED can confirm in a flash that a turn on pulse is being received from the ECM with the engine running. If you get good pulses, then the problem is likely with the injector(s). Another not so trusted method is to hold a long bladed screwdriver up against the operating injector body and the handle to your ear as though it were a stethoscope.

If you are cleaning your own injectors, keep the misting of volatile solvents contained, ground all static sources, keep sparks away, use a safe/low TURN ON voltage and keep the duty cycle lower than 80% to avoid overheating the coils. Keep in mind that when the injector shuts off, the back EMF from the collapsing flux field will produce a sharp spike, so always connect a back biased diode such as 1N4005 in parallel with the injector in any switched circuit as a discharge path. New pintle caps 2-252 are available from Injector-Rehab and should be seated on the injectors and the filters reinstalled using an arbor press. Replace 3.5mmCS X 8mmID Viton top and 3mmCS X 9mmID Viton bottom O-rings, lubing them with a little engine oil. Reseat them individually into the rail and reinstall the retention clips before attaching the fuel rail and final leak testing.

There are also many good injector cleaning services out there using the ASNU or similar bench flow matching systems. WitchHunter, LinderTech, AUS Injector and Injector-Rehab all do good work.

Throttle Pedal and Throttle Body

The AJ34 throttle body is all new, simplified and pretty trouble-free. The ECM automatically adjusts for TPS position, so virtually all that needs to be done is to keep the throttle butterfly clean using B-12. The electronic drive-by-wire throttle gives smooth accurate power delivery, although an overly robust pedal return spring continually fights you. There is a kick-down button near the limit of accelerator pedal travel that is akin to engaging warp drive. There is a special tool and procedure in the XK8 Workshop Manual for adjusting the cable that leads from the pedal up to the sender.

ZF 6HP26 6-Speed Automatic Transmission

This gear box is very strong and used in many brands of luxury sedans and sports cars, so there are a lot of them in service. The transmission has a single planetary and dual planetary (Lepelletier) gear set providing for 6 forward gears and supporting engines having up to 444 lb-ft of torque. This box incorporates Bosch Mechatronics, so there is always going to be noticeable shift lag. When placed in reverse, the ECM limits the maximum throttle body opening to 18°. ZF has their own Lifeguard6 filled-for-life fluid but all indications are that the fluid and plastic filter/pan should be changed out every 50K.

ZF claims that fluid shall meet Shell M1375.4 and I have seen conflicting evidence on the web that this is the case for the Pentosin ATF1. Folks have used any and all of the following: ZF Lifeguard6, the expensive Jaguar branded fluid, BG 312, Amsoil ATF, Mercon and Pentosin ATF1. I can't believe that ZF makes their own fluid, so I strongly suspect that Pentosin is their source, but that is not a fact. Different vehicle manufacturers also specify different fluids for servicing this same transmission in their cars.

Always confirm that you can loosen the fill plug before you remove the drain plug. Only about 6-7 qts of the total 10.6 qt fluid capacity are accessible during filter/pan drainage (the balance being trapped in the torque converter, lines and cooler). Refilling this way involves pumping fluid, running the engine, shifting thru the gears, measuring fluid temperature, pumping more fluid, all with the engine running until fluid drips out, then installing the fill plug, all the while working around hot exhaust pipes. Some claim that a better result is achieved by flushing the transmission via the cooler lines, since you can't drain all of the fluid by dropping the filter/pan. You will need to decide for yourself which method you prefer, as they both have different advantages. You may get an extended service interval (100K mi) with a flush, since you can get more of the old fluid out, but at greater cost in fluid.

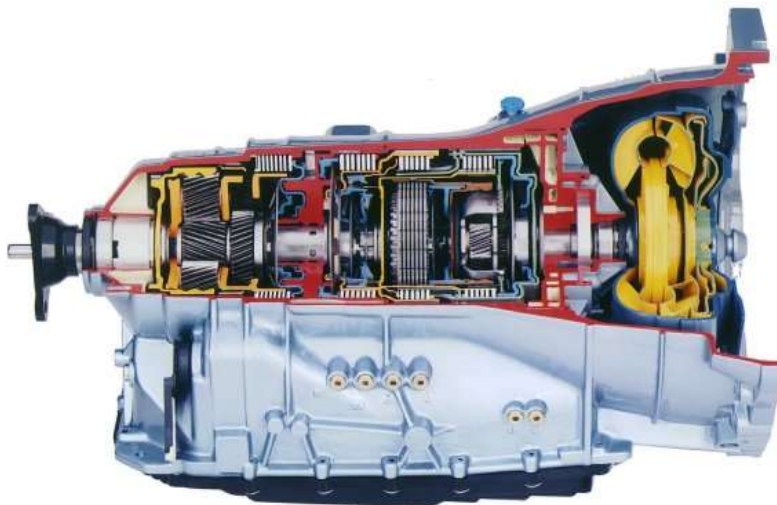

The Type A plastic filter/pan ATP 103178 is widely available. Early versions of this box used filter pan fasteners having T27 Torx driving recesses and apparently enough of them were getting stripped out during filter changes that ZF later switched to screws having the larger T40 driving recesses. Check yours out in advance and if you have the older screws, I recommend buying 21 of CTSC 0736 101

486 01 and install them with a little anti-seize compound. The connector sleeve CTSC 0501 216 272 01 should also be changed as long as the filter/pan is off. I don't know if the seals on this item are a high temperature elastomer, but Viton O-rings would be a good idea.

On the shifter surround there is a T40 Torx headed screw/plug that must be removed and the shifter lockout defeated if you ever have to limp home with a failed brake switch. The J-Gate feature allows you to select a lower limiting gear for better vehicle control in town or to manually downshift to get more power and/or torque as needed, without relying on the automatic transmission to shift based on generic load mapping. The Sport Mode button (UP is ON) on the console allows higher revs before hitting shift points to suit a more assertive driving style. The linear switch module C2N2467 (Find No. 27 in the line drawing below) may become intermittent in higher mileage vehicles and the problem manifests as a temporarily non-operative Sport Mode (and no Sport Mode light) with no J-Gate functionality (nor manual gear lights). Sometimes this occurs as a result of a poor shift or a temporary glitch in the system, so don't freak out if it happens once in a blue moon (it's happened only twice in the three years I've had the car). The system is reset by turning the car OFF and then back ON. The OEM shifter knobs on many XK8s are pretty pedestrian looking, relative to the rest of the cabin, so check out British Autowood's products. Their inlaid Mother of Pearl knobs are seriously sexy.

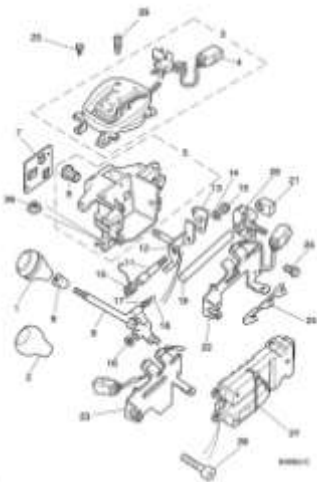

Driveline

The tubular steel driveline has a Guibo (also referred to as a Jurid or Elastomeric Flex Coupling) CBC8996 at the transmission end and a center stabilization bearing bolted to the guard pan for refinement. Guibo replacement needs to ensure that the critical balancing of the driveline is not disturbed. Always mark all bolt positions, keep them paired up with their specific nuts and don't allow anything to move until each item is restored to its original position. The Guibo has a directional arrow molded in, so make sure that you study everything before disassembly and that you have it facing the right way during reassembly. Guibos are good for ~150K mi, unless you're in the habit of hammering the drivetrain hard.



Differential

There is no drain plug in this differential and the fill plug is in a nearly impossible to access location near the top rear of the differential. Because of this, the rear axle assembly really needs to be dropped several inches to do the rear drive lubrication service. The conventional wisdom seems to be, when the pinion seal starts to leak, replace it and the fluid as well. I would do this service even if the seal hasn't leaked somewhere around 120K mi. I recommend that you do this work at the same time as you replace the rear shock/struts to save repeat labor. Unless you have a special installation, there were no Limited Slip Differentials installed in these cars. Jack up the rear of the car (so that the half shafts can rotate freely) yearly and grease the four U-joint zerk fittings, so moisture can't get in and they should last over 200K mi.

Exhaust System

The exhaust manifolds are stainless steel and attached with heat shields, long bolts and spacers to maintain proper tension and compensate for the different material expansion coefficients. This is a low thermal inertia system and the closely coupled catalysts are an important part of the design, but they are bare steel, so their exteriors rust badly. An EGR system was added in the 2003MY and plumbed to the intake via the right side exhaust manifold. The stamped metal gasket sometimes develops leaks here. There are two upstream C2C7359 wideband sensors (left photo) and two downstream C2C25956 conventional lambda (O₂) sensors (right photo). Both are 4-wire heated types, their lifetime is typically ~100K mi and they normally fail due to catalyst depletion. As they age, they tend to report leaner and leaner mixtures, the ECM enriches the long term fuel trim in response, exhaust gases get richer, producing more carbon monoxide and hydrocarbons, leading to poorer fuel economy. Replacing the upstream reporting sensors well before end of life is good practice and probably justifies their cost vs wasted fuel.



The XK8 exhaust system is a five box stainless steel design. In my opinion, Jaguar went too far in reducing the music from this engine, but they were doing what they thought best for the British market. Furthermore, the pipes tuck up so far above the rear axle that the bend angles are just too restrictive. There are several good aftermarket systems that replace the OEM system at quite a hefty price. Replacing just the aft boxes with straight thru pipes can get you a nicer sound. If you feel the need for a richer sound, replace all four aft boxes or go for one of the available "Cat Back" systems.

Electrical System

Of all the innovative technologies introduced by Jaguar in the XK8, the one bound to go largely unnoticed by owners is multiplexed electronics, not unlike the MIL-STD-1553B differential data bus protocol used in modern jet fighters. Though relatively new to automobiles, multiplex technology is thoroughly proven in the aerospace industry, where it has simplified wiring harnesses, reduced weight and improved overall system functionality.

In contrast to conventional systems, in which all features must be linked by dedicated hard-wired electrical connections, multiplexed systems control the various vehicle functions over a network of interconnected electronic modules operated by low-current switching. The control commands are encoded at the output device, such as a switch or a sensor, to be utilized at a specific destination. This coding technique (in computer terms, a communications protocol) enables many messages to travel over a differential pair of wires, rather than thru dedicated hard connections between modules. Shared usage of the communication pathway is very much like the system of roads our cars use every day: rather than providing each person in a town with their own personal road from home to their workplace, home to school and home to the supermarket, all drivers share main thoroughfares, connecting to the road system through their driveways, local streets and on/off ramps. Roadways can be shared by many users simultaneously, even though they are going to different places and doing different things, they follow agreed upon rules governing lane usage and right of way -- a protocol system.

The shared pathway, or data bus, brings with it an enormous boost in efficiency. With operational information made available across the entire multiplex system, control refinement advances greatly. As an example, communication between the car's various electronic control modules enables the transmission shift program to be altered when the traction control system is activated, helping the driver maintain control under slippery conditions. When the driver switches on the rear window defogger, that message is acted on not only by the appropriate heating coil control circuits, but also noted by the engine management system. In this way, the increased electrical demand can be anticipated, and engine idle adjusted to compensate for the increased torsional load on the alternator.

Relays are used extensively to keep switch contacts from having to carry high DC currents that produce pitting/arcng, but does mean that circuits become slightly more complex in the process. Having diagrams of the fuse/relay boxes located thruout the car, combined with a listing of which relay does what, could help out tremendously in a roadside emergency and allow you to trade out a failed relay in a critical circuit with one from a less critical circuit. The brown relays LJA6703AA are the most commonly used.

The windows are frameless so, to ensure a quiet interior at speed, Jaguar developed a system that drops the windows slightly to facilitate door opening and then drives them back up into their rubber seals after door closure. Jaguar recommends that the battery be disconnected before beginning work on any system and reconnected upon completion. Some cars apparently need codes to reset the radios and such, but I have had no such issues. Anytime the battery power is disconnected and then reconnected, the window limits will need to be retaught. To do this, sit inside, close both doors, close a window and hold the button until you hear a click (a second or so after closure), then open that window all the way and hold for another few seconds until you hear a similar click. Close the window, then open the door to confirm window drop upon open and window rise upon closing of the door. Do this for the other window/door. If the battery is left disconnected for long periods, other programming may be lost and require re-training. If it keeps happening, check the battery and/or charging system. I like to make sure the car is unlocked and the keys in my pocket anytime I disconnect the battery. **If you disconnect the battery, DO NOT close the boot lid out of force of habit, as you may find it difficult to operate the seldom used manual boot lid key mechanism hidden in the right rear badge to get it open again.**

The OEM battery is a wet cell unit vented to the outside thru a tube. It is usually good for at least 5 yrs. Top off the electrolyte in each cell once a year, using distilled water. Suitable equivalent Absorbed Glass Mat (AGM or VRLA) maintenance free batteries are also available.

The internally rectified/regulated alternator is cooled by forced-air (in contrast to the type F water-cooled unit in BMW V8s) coming from the underside of the car thru a fixed tubular C-shaped plastic tube. Cooling air is drawn into this tube with the aid of a removable flared plastic duct HJA4477AD (held to the steel cross bar by a single M5 bolt). This duct prevents access to the oil filter, so it is usually the first thing removed and the last thing reinstalled during an oil change, often getting misplaced by careless service personnel. It tucks up above the tubular duct at the rear (it is split on the aft end to allow the center portion to get captured inside the tube) and then clips into the radiator support at the front. The duct is not shaped like a NACA vent on aircraft, so I question its efficacy. If yours is MIA, you should probably still get a new one. For every 10°C cooler you can keep the rectifier diodes, you will theoretically double their life.

Along the sides of the engine compartment are cable routing troughs that tend to collect all kinds of muck, so blast them clean with a pressure washer periodically. Along these same lines, the lower body sill rails undershoot the wheelwells, creating the ideal gravel trapping opportunity. Blast these areas clean as well. The front splash guard tends to fill with small pebbles, leaves and such that should be cleaned out from time to time.

The molded plastic end retainer tabs on the side marker lights (and other similar polystyrene or polycarbonate lamp fixtures) stress crack over time so, while they are still new, wedge some EPDM sponge rubber between the body and the tab for support and you will extend their life. This approach also works well to reinforce the fuse box cover latches that lose their mojo in the extreme engine bay heat.

The battery in the key remote is CR2032 and the directions for battery replacement are in the Driver's Handbook. Changing the battery properly DOES NOT require reprogramming. If you need to buy a new key fob, there is also a procedure to teach it posted on the Jag forum. The presence of a power antenna instead of a hidden dipole or short stalk that won't collect crap from the air and jam up boggles the mind. When you need to replace the power antenna mast LNA4134AA, it is \$20 from AntennaMastsRus.com as their part A068. The plastic track teeth face aft.

There is an Inertia Cutoff Switch tucked up behind the plastic panel just forward of the bonnet release latch that shuts off fuel, opens door locks and such during an accident sufficient to trip it. If it gets tripped it will need to be re-latched when it is safe to do so. You will find that the driver's side systems wear out before the same systems do on the passenger side due to higher usage.

Just a few words about British color coding. Wiring Colors are abbreviated in textual manuals.

B is Black	G is Green	K is pinK
LG is Light Green	N is browN	O is Orange
P is Purple	R is Red	S is Slate
U is blUe	W is White	Y is Yellow

A browN wire with a White tracer would be NW.

Black base colored wires indicate ground circuits, the wire connecting an electrical unit to ground, usually the car's metal chassis. A browN base colored wire is HOT or one that always has power present and is not fused.

Since the browN wires run different circuits, it is necessary to further differentiate them with the tracer color. The tracer is a different colored stripe running the length of the wire to indicate the particular

job of that wire. Therefore a brown wire with a Yellow tracer is for the generator warning light while brown with a White tracer is for the ammeter.

The blue wires are for headlights, with plain blue being Power to the dimmer switch, while the Power from the switch is denoted two ways. Blue/Red (UR) is for the low beams and blue/White (UW) is for the high beams and the indicator lamp.

White denotes a circuit that is powered when the ignition is ON. A plain white wire runs the fuel pump, ignition relay, and various fuse box connections. White with Red tracer (WR) is the power to the starter solenoid, and White with Green tracer (WG) is power to the radio. White with Black (WB) is power to the ignition coil unless there is a ballast resistor, then the wire is White with Light Green (WLG).

Slate indicates circuits that are hot when the ignition is OFF, such as emission control power. Purple is for always hot circuits with fuses such as courtesy lamps (PW) or key buzzers (PG or PK).

More info can be found at <http://www.jcna.com/library/tech/tech0014.html>

Independent Suspension

The sophistication of Jaguar's suspension design has long been among the most highly ranked of the marque's traits. The XK8 basic suspension system design relies on long-proven components--independent, double wish-bones up front and an independent, control-arm layout at the rear. To prevent road surface noise and vibration from reaching the cabin, suspension components are not attached directly to the XK8 body. The inboard ends of the upper and lower wishbones attach to a cast front cross beam, a structural member which spans the car from side to side. This intricate aluminum alloy casting is light and very torsionally rigid. Jaguar further enhanced its durability by heat treating and applying a Dacromet protective coating to minimize the galvanic couple where aluminum meets steel. The suspension arm bushings are specially tuned to provide the proper degree of compliance when subjected to cornering loads. Besides the suspension arms, the forward portion of the engine's weight is carried by tuned hydraulic (oil filled) motor mounts attached directly to the cross beam. I'm told that the bolts attaching the crossbeam to the frame can seize in situ after many years of galvanic action so, if you do manage to get them out, you may need to replace them and use anti-seize compound upon reassembly.

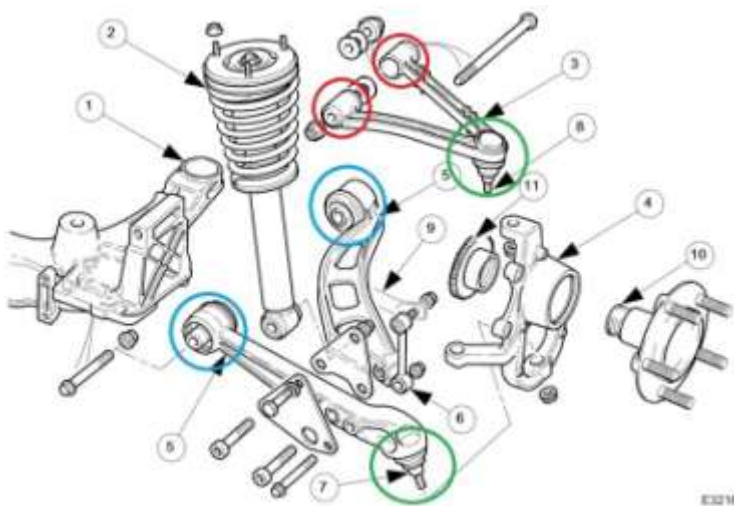

Despite the good design and progressive springs up front, low speed yields a somewhat harsh ride over rough road surfaces like brick or cobblestone. At freeway speeds everything seems just about right, although the front-end rebound damping seems a bit light to me. A front anti-roll bar reduces body lean and the car corners as though it were on rails. The line drawing above shows the parts and replaceable bearings and bushings. The upper ends of the coil springs, which surround the dampers,

mount directly to the body, reducing the load on the lower control arm bushings to improve durability. Front wheel hub bearings W0133-1613882 (SKF BAH0028) are a robust sealed double cartridge-type, greased for life and don't require repacking. They are under a lot of stress and their life is around 100K mi. Replacing them is possible for the DIY'er as long as you have access to a pickle fork, a slide hammer and an arbor press. Some owners merely replace the entire hub carriers rather than wrestle the bearings out but, if you do this, you will definitely need a new alignment.



The XK8 rear suspension design shown in the line drawing below reduces the natural tendency of the car to squat under acceleration. Like the front end, the XK8 rear suspension utilizes a control-arm design, with the coil spring and damper combined into a single unit. The springs are seated directly on the cast-iron transverse lower wishbone, not the damper, which reduces friction for better ride comfort and noise isolation. The half-shafts serve as the upper suspension links.

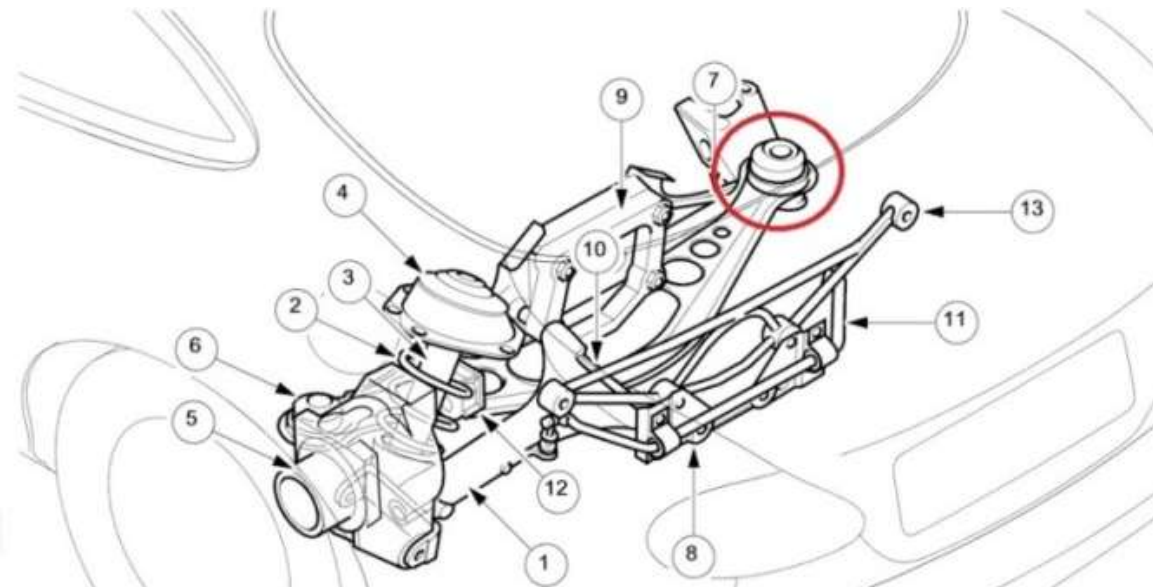

The entire rear suspension is mounted to a stamped steel carrier cross beam, that is bolted to the body through elastomeric bushings tuned to isolate road harshness. In addition, the lower control arm pivots allow some deflection toward the rear when the wheel is subjected to the sharp impact of a pothole or bump. A rear anti-roll bar helps control body roll in cornering. Due to the limited space, a slim spring compressor like the Sir Tools ST 9050 is needed for the rear end damper work. The rear wheel bearings W0133-1620280 are not sealed for life and should probably be checked before 100K mi.

I am a big fan of Powerflex brand urethane bushings when the time comes to replace any of the aging OEM elastomeric bushings used thruout the suspension. Be sure to lube the inside surface of the anti-roll bar bushings with the included grease or they are guaranteed to squeak.

The front of the car is pretty low (~5 inches at the front bumper fascia on my car), so you must learn to adjust your approach angle when negotiating driveways and gutters and never take them straight on. A 45° approach/departure with no braking dive is the best practice, or you will certainly end up

scraping the underside of the bumper fascia. Still, I end up sanding and repainting the underside about once a year.

Rack and Pinion Steering

Continuing a long-standing Jaguar tradition, the XK8 steering system is a rack and pinion design providing a suitable level of driver feedback without compromising its luxury-class smoothness and feel. Based on ZF Servotronic components, Jaguar's advanced steering system incorporates speed-sensitive variable power assist and a variable steering ratio. Speed-sensitive power assist: the hydraulic system providing the power assist delivers full boost at low speeds for easy parking but, as vehicle speed rises, the assist lessens to give a well-weighted, confident feel to the steering at highway speeds. Due to the high assist at low speeds and the wide front tires, driving on rippled/scalloped road surfaces results in some tramlining, but you can't have it both ways. While some less sophisticated systems provide variable assist by cutting the flow of fluid to the steering rack itself, their effectiveness is hampered by the need to maintain sufficient flow for emergency evasive maneuvers at high speeds. Using the hydraulic reaction principle to vary steering effort enables the XK8 to offer both world-class steering feel and power assist that is always available regardless of speed.

To further refine steering feel during straight-ahead highway driving, the steering gear valve incorporates a positive center feel torsion bar. As the name implies, the torsion bar twists a slight amount in operation, effectively programming an on-center position into the action of the steering valve at small steering angles, improving stability in conditions such as crosswinds. When the steering wheel angle exceeds a predetermined amount, the torsion bar reaches the end of its travel and the control of assist levels is assumed by the Servotronic system. Variable-ratio steering: the steering rack is a design in which the rate of road wheel movement quickens as the extremes of wheel travel left and right are approached. This makes parking less tedious yet provides an appropriate level of assist--not overly sensitive to small steering wheel movements--for excellent stability at highway speeds. Some dislike the speed sensitive power assist the ZF system provides, leading them to remove the Servotronic Relay LNE2100AA near the steering column to restore a less sensitive feel.

To reduce lateral friction forces on the front tires, the steering layout of the XK8 provides near-100% Ackermann geometry (dynamic toe-out). The desirability of this characteristic arises from the fact that, in a turn, the left and right front wheels describe circles of differing diameters (the tire on the inside of the turn describes a smaller radius circle than the tire on the outside of the turn). As a result, the tires need to point at slightly different angles in a turn, though they still must return to parallel alignment when the car is again traveling straight ahead. This is analogous to the aerodynamic condition known as adverse yaw in aircraft design, where offsetting the angles of aileron bell-crank arms (control arms on cars) give the control surface (front wheels on cars) on the inside of the turn both the greatest initial authority and the most drag. If the steering geometry does not achieve the correct differential angles--ideally 100% Ackermann in non-racing vehicles--the result will be coarse turning at low speeds and higher tire wear.

For some reason(s) steering column tilt and/or reach motors don't always work properly. This may be due to friction inherent in the OEM Bosch position sensors (the little black plastic box on the end of each motor). It seems that friction/drag in the potentiometer and/or the drive system causes the current limited controller circuitry to power down the motor(s) before they can drive to their memory set position(s). To attempt to improve this condition (the reach motor is on top and the tilt motor on the bottom of the column) snap the box off the end of the offending motor (my problem was just with the tilt motor), remove the screw holding the clamshell enclosure together, unsnap the two catches and remove the green spindle. Under the spindle is a wave (spring) washer. Flatten this wave washer substantially and clean out all the grease in the gear teeth. Reassemble the box, verify that the spindle now turns quite freely and snap the box back on the motor. If you remove the entire motor from the steering column, run it on the bench for 15-30 minutes. This ensures that the brushes are well bedded-in on the commutator. All of this may help, but I confess that I know of no definitive

solution to the tilt/reach motor problem and would welcome constructive comments from knowledgeable technicians.



Stability Control

Standard equipment on the XK8 is Automatic Stability Control (ASC), which reduces drive torque to the wheels by controlling the throttle position, ignition timing and fuel supply to the cylinders. An optional TRAction Control (TRAC) adds brake intervention, using the anti-lock brake components to slow a spinning wheel.

In both systems, wheel spin is detected by the anti-lock brake sensors after comparing information supplied by all four wheel-speed sensors. Both systems may be manually canceled by pressing a switch above the center console to power out of deep snow or when using tire chains. Automatic stability control is operational at all speeds to enhance car control in slippery conditions. When wheel spin is detected, the anti-lock electronic control module calculates the engine torque level that can be utilized without causing the tires to slip, based on information from the vehicle's Controller Area Network (CAN).

First, the throttle angle is reduced, but because the effect of this action is not instantaneous, two further measures are taken. Ignition timing is retarded (the spark plug fires later than normal) and fuel to the cylinders is cut off until the proper throttle position is reached.

Brakes

The XK8 brake system uses the Ate (Alfred Teves Engineering) Continental MK25 4-channel DSC/ABS unit in a split front-rear arrangement. Unfortunately the OEM single pot single acting brake calipers are somewhat anemic. I would like it very much if there were a good low priced option (<\$1K) vs the big chunk of change needed to upgrade to Brembos or similar. The braking ability is there if you get on the pedal quicker and harder but it's just not as responsive as my BMW X5. I use Drilled and Slotted Centric Power Stop Discs, Centric Semi-Metallic Pads (virtually no dust, much more bite than OEM pads and their stopping power only improves as they get warm) and Ate DOT4 fluid. I used to use their Superblue Racing Fluid, but as of Aug 2013, it is no longer carried in most US Autoparts stores, due to a twenty-year-old DOT decree that automotive brake fluid be clear or amber to avoid confusion when servicing vehicle fluids. Cool Carbon and Akebono pads are also good choices, but may be noisier than the softer pads. The limits on rotor wear are 26mm for the front and 18.5mm for the rear. Speedbleeders are available that make single person brake system bleeding much easier (two SB8125L-SS in front and two SB8125-SS in the rear). They also sell a tubing equipped plastic recovery bag (like an IV bag) that catches the expelled fluid for easy disposal. Jaguar recommends the following bleed order: LF, RF, LR and RR.



ABS Control Electronics are in the black box attached to the hydraulic block and can be removed for repair separately from the block. ABS and DSC require that all four wheel sensors report or the system will shut down and turn on the brake warning light. All the connections from the circuit board in the box and the hydraulic block are inductive. Some owners have experienced solder joint fractures to the circuit board that are easily rectified if you know how to solder. Unfortunately the Jaguar brake fluid lines are dressed/formed down across the face of the box, making it tough to remove without draining the system and undoing the hard lines. On most BMWs, separating the Control Electronics from the hydraulic block is a simple matter, as they do not route the hard lines in a way that obstructs black box removal. The harness connector has a sliding plastic end bar to seat and lock the connector in place and it needs to be pried out from the end to disconnect the harness.

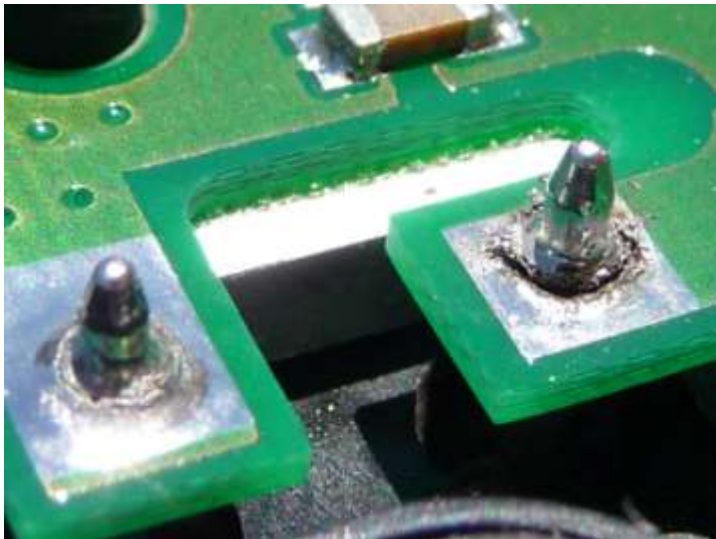

Wheels/Tires

OEM chrome wheels can experience plating separation over time, leading to slow escape of air from the tire bead seating area. You need to get your tire guy to inspect the plating all around the bead seating areas during tire mounting and advise you, **but this is a bad time to find out that you need a new wheel**. Another possible way of assessing their condition is to look around the perimeter of the center growler badge. If you see chrome separating (a raised area) in this region, then you can be assured that the chrome in the tire bead seating area is also compromised. Newer plated wheels that do not exhibit this concern are available, and these may be recognized by the presence of grey paint instead of chrome plating, across the inside of the wheel in the bead seating areas. This issue is covered in SB204-06 and affects more than the stated serial number range.

Many XK8s originally came with Pirelli P-Zero tires. Mine came used with Hankooks, but I like Michelin Pilot Super Sports because they are asymmetrical, dual compound, super sticky and quieter than Pirellis. However, they do have a rather straight cut tread that contributes to groove wander. Whatever tires you put on, you will generally get twice as much mileage out of the front set as the rears. The rear set will usually only get you ~20K mi, depending on road surfaces and how hard you get on the pedal. The low profile tires make wheels prone to curb rash if you are careless in picking your parking spot, so stay well clear of curbs. When you do need to buy new wheels, the aftermarket is your best option. Many of the OEM wheels are available from Keystone.

The tire industry has a quasi-standard color-coding methodology that identifies the lightest point on the tire and/or another point of variation in the tire carcass, but it appears that many tire service companies either don't understand or don't follow the guidelines, because I see lots of tires mounted willy-nilly on new vehicles.

These cars came with a lot of different wheel/tire size combinations over the years, but I like the sizes I have. Their grip is great in all conditions except freezing, they are quiet and they turn in/out well. It seems to me that Jaguar could easily have done a better job of either zinc plating or painting the wheel hubs, as they become quite a rusty mess after only a few years of moisture ingress in and around the center caps. I hit them with a wire brush and then a light coat of VHT or Rustoleum enamel from a rattle can when doing the first brake job. These wheels are hub-centric, meaning they have circular hub centering bosses and use flat washer (vs conical base) type lug nuts. Put grease on the wheel center bosses to keep them from sticking to the painted steel hubs and a drop of oil on all stud threads.

The OEM wheel center caps that came on my car looked pretty cheesy. I bought nicer looking replacements online and they are available in a variety of styles/colors. Why would Jaguar "value engineer" their caps/badges to cheapen their appearance in this manner? The boot release button also begins to look shoddy after a few years of normal use.

Windscreen Washers/Wipers

The wipers are 21" and have a short length of black tubing traveling from fittings in the windscreen trough thru the wiper arms to the arm mounted nozzles. The tubing seems to be of good quality, but won't last forever, so watch it. The passenger wiper arm pivot is in the center of a very strong low pressure area creating a vacuum/venturi effect near the rear edge of the bonnet at speed (like blowing across an open bottle). The faster you drive (above 90 mph) and the longer you drive fast, the more this irresistible force wants to suck the plastic cap up and off of the wiper arm recess. It's Bernoulli's fault. I've lost two, so now I push it back down every time I see that it is riding up even slightly and I also keep a spare. The driver's side doesn't have this problem, being that it is tucked so much deeper under the bonnet edge that the low pressure doesn't act on it axially. If you lose the cap GJA8966AB, the nut and shaft will rust due to exposure and the tendency of the recess to trap moisture.

The washer fluid system lower filler neck-to-reservoir joint is a poor fit and will leak as the rubber grommet dries out over time. Remove the unit from the left front wheelwell, disassemble the reservoir to filler neck joint. Remove the large rubber grommet and clean everything in the vicinity of the joint well with Isopropyl Alcohol. Get some silicone aquarium sealant (it has better adhesive properties than some of the other caulking silicones) and butter up both the grommet outside groove and inside surfaces with sealant. Reassemble the grommet, neck and reservoir then reinstall in the car to cure in situ.



Recent testing has found that windshield washer fluids not containing sufficient alcohol (Methanol was removed to render them less toxic if children were to drink them) can foster the growth of Legionella in warm conditions and spread the bacteria as the mixture aerosolizes during use. I've always added 3 cups or so of denatured alcohol (you can use isopropyl instead if you like) per gallon to all washer fluid I buy to cut road grime better and improve resistance to freezing during winter. This also makes washer fluid unable to support bacteria growth (sailors used to drink ale or watered down rum on voyages because straight water would quickly go stagnant). You needn't add lime juice, since windscreens aren't prone to scurvy.

Convertible Soft Top

The decision to use a soft top -- rather than a hard panel -- was reportedly a deliberate XK8 styling choice. The XK8 soft top fabric and liner are attached to a folding aluminum framework engineered to provide a low "stack" height. You can operate it easily, even inside a garage with a fairly low ceiling. Operation requires pressing and holding a momentary rocker switch on the center console until a chime indicates first the start, then about 20 seconds later, the completion of the soft top close or open action, while traveling at up to 10 miles per hour. Latching, unlatching and rear side window operation are all automatically sequenced, but you must continue to hold the button down beyond the chime for the entire erection cycle (including the windows) to complete. When using the key lock method to lower the top, the door windows are driven to their fully down positions.

Here in the states there were many early reports of hydraulic line failures under warm to hot conditions. The dreaded "Jaguar Green Shower" happens without warning. The hose failures occur in the windscreen frame but are virtually unheard of in the UK, so heat is definitely a factor here. Two methods of lowering the peak pressure in the system have been developed. The left photo below shows the 0.2 Ohm 100W (actually I put two 0.1 Ohm 50W resistors in series) pump voltage dropping resistor method and the right photo, the LSI pressure relief valve method. The valve solution is probably superior, but at a greater acquisition cost and considerably more installation work. Use only Pentosin CHF11S (green synthetic fluid) in these pumps and if you have any other fluid (earlier XK8 model years used a different brown fluid that gelled in the small diameter lines over time and temperature cycles), it must be completely purged/flushed or bad things will happen. The Soft Top hydraulics are driven by a PowerPacker brand pump that spikes to 1600 psig worst case and the hose problem has been most strongly associated with Parker hose types 303 and 363 during opening. It is unclear to me when/if these hoses were discontinued. You can read more at JagRepair.com.

The soft top hydraulic system was designed to be very compact, using small diameter hoses and cylinders, necessitating high hydraulic pressure to do the hard work of moving the soft top and actuating the latching mechanism over a great distance. This is hard on the components and the environmental conditions the system must endure may have been difficult for the UK engineers to anticipate, simulate and test. The pump portion of the system seems robust, but the plumbing itself

and/or the termination of the fittings to the hose may be suspect. You really should install one of these two solutions or you may ultimately have a mess on your hands.



JagWrangler.com has a spiffy modification that, once installed in the driver's door, will allow you to remotely control soft top operation using the headlamp button of your key fob remote. Certain areas of the soft top inner liner (probably a polyester material that looks and feels like a light fleece) will get sooty along with all of the rear seat surfaces (same as the radio antenna) if you are driving around a lot with the top down. I use a combination of 70% Isopropyl Alcohol on a microfiber towel and a little steamer vacuum cleaner (VAPamore MR-50 that I have modified to allow both the steam generator and vacuum motor to run simultaneously) to clean the liner periodically.

Cabin Seating and Interior

The OEM separate headrest type seats were a poor choice for a car of this caliber and, though adequate to the task of driving, they fail big time in the cornering department. Due to quirks of their design, they also have a tendency to develop creaks over time with occupant movement, requiring you to apply some lithium spray lubricant up, in and around the hinges and folds. There is also an SB for a fix to the seat riser end float. The seat position control electronics sit in a plastic enclosure under the front of the seat bottom and after years of seat loading impact, the cases or lids can crack and rattle. There is an SB that offers a replacement lid C2N3565. The range of seat motion is somewhat limited for long legged drivers and the seat can only go back so far as the rear seat bolster will allow. Top up, there is just enough head room and I'm 6' 2". I have the seat base height all the way down both front and back.

The headrest drive cables can be troublesome, but there is an SB fix that fellow Pastafarian Reverend Sam has kindly made a YouTube video of, describing correcting the sheath length, so that the internal cable ends fully engage in the drive spindles. Pull the internal cable out and use a Dremel type tool with a carbide cutting disc to girdle the sheath and a good quality 1/2" starting diameter semi-rigid wall heat shrink tubing having a meltable adhesive inner liner (meeting AMS-23053/4-105-0) to rejoin it (don't use duct tape) and this fix will last the life of the car. The headrest drop feature is controlled by a microswitch on each seat frame. The seat side release lever allows the seat back to tilt forward, actuating the microswitch and running the motor to retract the headrest into the seat back. When the seat back is returned to its normal position, the microswitch allows the headrest to return to its programmed position. Be aware that these microswitches are snapped onto the seat frames facing the driveshaft tunnel and can be easily dislodged by careless vacuuming of the interior.

The driver's seat lumbar bladder was in the wrong vertical position for my back, but it was easily remedied by disassembling the rear of the seat back and changing the tie wrapped height of the bladder relative to its rubber mounting web.

Starting with the 2003MY there is an internal flux gate compass fitted to the rearview mirror. The cup holder is completely laughable, but a rebuild kit is available if you break yours. The center console

armrest “goody tray” cover foam gets compressed, the leather starts to ripple and the whole thing begins to look shoddy over the years. Better foam is probably a good retrofit. Rev Sam’s got this, as well as many other XK8 DIY activities, covered in YouTube videos too.

Another weak area is the door weather stripping, but only in two areas. The molded rubber can split where the window glass edges exit at the front just above the mirror and at the rear just above the door latch. The cost of replacement is significant and installation laborious. There is a solution that has worked for me. For the front split, just trim off the split sharp corner and smooth it into a more rounded corner with a Dremel tool sanding drum. For the aft end, buy some Permatex Black Rubber Sealant #80338. Put some in a non-waxed paper mixing cup, add Acetone to reduce it to brushing consistency and make sure it’s mixed well. Clean and scrub the rubber repair area well using Acetone on a paper towel to get any silicone release agents off. Using an acid brush, apply the mixed liquid in multiple thin wet coats. If you need to, use masking tape to hold any split areas together and drip some of the rubber mix down the inside of the rubber. Let setup overnight and reapply as necessary until the area looks like new.

I like dash mats in all of my vehicles and Cover King makes a good velour one. Just make sure that you get the Velcro anchors stuck well to the glare shield surface, as having a dash mat fly up in your face on a convertible at speed could be really dangerous. I found that the acrylic adhesive equipped Velcro didn’t work well (the acrylic adhesive softens in the heat of the sun), so I ended up using Acetone as a cleaner and Permabond Contact Cement to bond the anchors down. Gorilla glue may also work well, but use it sparingly since it foams up as it cures.

The windshield glass is soft (PPG or similar) and instead of cracking as do windshields on Japanese imports, the glass just pits from repeated small road gravel hits. This is also an issue with BMWs, but I would rather have pits than cracks that propagate all the way across a windscreen. Get a good repair guy out to do the windshield replacement when you no longer can stand the pitting (it looks the worst when looking directly into the sun). The wiper arms and tray in front of the windshield have to be removed prior to accessing the glass. There are adjustment screws inside the rear quarter and door panels to align window tracks and set their final window resting (closed) positions.

There is a microswitch inside each door on the latch mechanisms that can degrade over time and there is a fix for it, so when your door doesn’t sense that it has been closed and bumps the glass up, and you have reset the window glass limits, it may be time for a new switch.

Regarding “popping” door hinges, the hinge foot attached to the body shell shears from one tangent point of the bolt clearance hole to the opposite tangent point as the door is opened and closed. It is basically just snapping back and forth because the bolt has loosened, and Jaguar hasn’t shake-proofed the fastener. It normally occurs on the driver’s side first, because that’s the door that gets opened and closed the most. Remove the bolt and reinstall it using some Loctite 242 and retorque securely (about 5 ft-lb [60 in-lb]), and your problem is solved.

The vanity mirror lamps are not wired through their hinges, so they only work with the visors stowed in their clips.

Climate Control

On the knee bolster there is a little plastic grille behind which lies a thermistor and fan for the climate control system to reference. This item gets dirty so the climate control system can’t accurately sense the temperature of the interior and appropriately throttle the system’s resources. A little bit of dash disassembly is required using plastic pry tools--go slowly so you don’t break anything. Clean the thermistor with a little Isopropyl Alcohol and reassemble. It might be good to power up the fan with 12VDC to ensure that it still works. There are also concerns with the heater system coolant circulation pump getting gunked up and the commutator brushes wearing out over time. Apparently the brushes are not of a size that is readily available so some are sanding down larger ones to fit. Access for this disassembly is difficult as it sits down near the transmission.



Active Restraints

Extensive safety considerations are engineered into the XK8. There is a sophisticated onboard system constantly assessing the occupancy/position of those in the cabin and providing for optimum deployment of the airbags under a wide variety of conditions. Dual seat bolster airbags are provided for the driver and front passenger, along with pyrotechnic seat belt pre-tensioners to take up seat-belt slack during impact.

Pollen/Cabin Filter

There is no OEM interior pollen filter or even a filter box under the bonnet of any XK8s sold in the states and seriously, do they even work in convertibles?

Engine Bay Heat Soak

As I indicated in the beginning, there is never enough room to easily access some system components so, due to the fact that the engine bay is largely full of, well ... engine, there is little room for hands and tools. Heat produced by the engine and conducted through the attached alloy structures needs to be forcibly ejected, so prolonged "stop and go" traffic should be avoided. This is a touring car made for the open road. As the hot engine is shut down, all that waste heat bakes into the surrounding structures including the fuel rails, wiring harnesses, plastic and rubber parts. Heat drives out the plasticizers and emollients in plastic and rubber parts respectively. There are many difficult to reach/replace hoses in and around the firewall that are subject to drying out and cracking, some with dire results. The radiator fans are electronically controlled and don't run at all when the engine is first started cold, run slowly (electrically connected in series) at coolant temperatures of around 190°F and then run at full speed (electrically connected in parallel) at coolant temperatures around 204°F. In my opinion, the designers really should have programmed the controller to keep power on the fans at lower temperatures for several minutes following hot shutdown to combat this heat trapping tendency. Jaguar should also have provided louvers in the bonnets of all of these cars (not just the XKRs). The point being, heat will have a lasting cumulative crispy critter effect on the contents of the engine bay, so inspect, maintain and act accordingly.

Protection

Keep all hoses, and for that matter all rubber items (except the serpentine belt), well coated with a good silicone oil spray for longest life. I recommend using industrial food grade low viscosity spray CRC 03040 (Fastenal carries it) for large area coverage and Easy Rider RT630A (paint ball aficionados use it) for coating small bushings, because it is thicker and clings better. Dupont makes a Krytox Spray containing PTFE for bicyclists that has numerous automotive applications.

If your XK8 is a daily freeway driver, you do need to protect the front end against road FOD. Sadly, the C2S4496 Front Bonnet Protector (black vinyl bra) was never reconfigured for the front end changes made in the 2003MY, so it ends up being a marginal fit around the driving lamps and the intake areas. The intake mouth of the newer grille is a different shape and deeper, so the plastic clips

don't reach. You will need to make your own bungee attachments to adapt it to the 2003 – 2005MY range, preferably scallop the lower portion to clear the bottom intake and re-hem it so as not to block air flow to the lower radiating elements. You will also need to make some loops (I formed some of .032" dia stainless steel aircraft safety wire) to hold the bra corners up and back using the fir tree clips of the wheelwell liners as anchor points. A clear protective film bra is also available.

Convertibles get very dirty inside when you drive around a lot with the top down. I use Lexol wipes to clean, then Surf City Garage Voodoo Blend Leather Rejuvenator to treat the leather. The outboard piping on the driver's seat back and surrounding area will get rubbed raw by your derriere long before any other leather surface except the console armrest, shows wear, so protecting this area with a pad or something similar may be a good idea. New seat skins are available from GAHH, but are quite expensive.

Other protectants may be needed in different climates. Noxudol 750 anti-corrosion treatment cavity wax should be applied on and/or into all places you can get to with the included snaky hose that might be subject to moisture ingress and road salt effects. Remove the plastic front wheelwell liners for access and apply wax in these areas too. If you can get the car up on a lift, look for lower areas that are prone to moisture or rusting and apply it (just don't get it on braking surfaces or items that must move freely without binding). The steering linkage knuckle U-joint in particular has a tendency to rust badly, so wax it regularly.

For soft top external fabric cleaning and protection, I use Raggtopp to clean and treat the fabric twice a year. Any little nicks in the paint get a little attention and I use Automotive Touchup brand paint from a brush bottle or a rattle can. For the paint finish, I clay the car every year and apply Mothers FX Syn-Wax.

I don't always treat the fuel injection system, but when I do, I prefer B-12 Chemtool. Stay clean my friends.

There isn't much plastic on the XK8, but the best plastic treatments I've found are the Meguiar's and Mothers brands.

Lighting

My XK8 has the OEM halogen headlamps and I have no plans to convert to HID, as they are quite satisfactory as is. The headlamp lenses are non-safety glass (quite sharp when shattered) and, as a result, prone to road FOD damage. I recommend applying the X-Pel 3M protective film appliques (~\$50) ASAP or you may be buying a \$260 lens (left W0133-1657394, right W0133-1657395) soon. The film kit I bought had six precut pieces to cover all the individual headlamp glass surfaces including the driving lamps and washer nozzle half-moons.

Halogen lamps are available in various enhanced performance versions and should always be used in pairs so that the color and intensity of the beams on both sides are the same. All other lamps are available in Long Life or LED equivalents. It's a personal thing, but frankly, when cars with LED lamps brake in front of me I find it to be too startling, so I prefer incandescent brake lamps. It was nice of Jaguar to give us an unused spare lower center position lamp that can be traded out in emergencies for a failed rear/stop lamp in each fixture. Replacement lamps are as listed below:

<u>Position</u>	<u>Sylvania P/N</u>	<u>Description</u>
• Front Lo (Dipped) Beams (2)	H1	STR 55W Halogen
• Front Hi Beams (2)	9005	RA 65W Halogen
• Front Parking (2)	2825 LL	5W
• Front Turn Signal (2 YELLOW)	7507A LL	Y21W
• Front Fog/Driving (2)	H1	STR 55W Halogen
• Front Side Marker (2)	2825 LL	5W

• Door Puddle (2)	2825 LL	5W
• Glove Box (1)	3893	T4W or LED
• Interior Panel (4)	194	LED
• Interior Footwell (2)	2825 LL	5W
• Interior Map (2)	2825 LL	5W
• Rear Side Marker (2)	2825 LL	5W
• Rear Tail/Stop (2)	7528	21W/5W
• Rear Center (2 Spare)	7528	21W/5W
• Rear Turn Signal (2 YELLOW)	7507A LL	Y21W
• Rear HMSL (1)	2825 LL	5W
• Rear Back Up (2)	7506 LL	21W
• Rear Fog (2)	7506 LL	21W
• Rear License Plate (2)	2825 LL	5W
• Rear Boot (2)	6418 LL	5W or LED

OBD2

The OBD2 system is conventional and an appropriate scan tool (I have an Innova 3130) will return Diagnostic Trouble Code (DTC) P1111 when all systems are “in the green”. Get a good list of Generic and Jaguar specific DTCs so that, when your car throws a DTC you don’t recognize, you can at least have a rough idea of what is going on. Some tools are more sophisticated than others and many auto manufacturers are very keen to keep their OBD2 details proprietary. The Autologic, AutoEnginuity and ScanXL tools are high-end tools for professional shops, the Snap-On Ethos is a good mid-range tool and the Innova Equus series offers decent low-end tools for the DIY’er. Scan your car’s systems Key-ON Engine-OFF (KOEO) and read the live data Key-ON Engine-Running (KOER) while driving at varying speeds when things are running well, so that you will be able to recognize normal range readings. Some live data can be captured in memory and subsequently uploaded to your PC to produce graphs and reports. Do not begin replacing things on a single throw of a given DTC, but do use the tool and OBD2 system to help you to baseline, monitor and troubleshoot your car’s systems and look for trends over time. Try to develop a good diagnostic sense that allows you to proceed logically to narrow down and pinpoint the malfunctioning item in the system. There are a number of YouTube videos that can help to hone good troubleshooting skills.

As with all systems, their ability to function as designed depends on each component doing its job correctly and consistently. OBD2 diagnostic capabilities can help you to pinpoint which of the many components is the slacker in any given subsystem, allowing you to channel your diagnostic and corrective efforts methodically toward those items most logically responsible for the fault. Remember Occam’s Razor and attempt to strongly correlate or isolate the problem to a single component. Problems are often just something simple like a failed sensor. Take your time in sorting thru the evidence and, like Sherlock Holmes, try to eliminate the extraneous to arrive at the truth. Keep in mind that the axiom, “If it ain’t broke, don’t fix it” is also true, so try not to break other things as you fix your initial problem. Modern cars are designed and built for ease of assembly and not necessarily for ease of repair.

Following are some of the normal range OBD2 Parameter Identifications (PIDs) accessible by my tool:

Fuel System 1 (KOEO Open Loop, KOER Closed Loop)
 Fuel System 2 (KOEO Open Loop, KOER Closed Loop)
 Calc Load (KOEO 0% KOER 0 to 100%)
 Eng Cool Temp Sensor (-30 to 260°F)

Short Term Fuel Trim B1 (-10 to 10%)
 Long Term Fuel Trim B1 (-10 to 10%)
 Short Term Fuel Trim B2 (-10 to 10%)
 Long Term Fuel Trim B2 (-10 to 10%)

Fuel Press Sensor (50 to 60 psi)
Man Air Press Sensor (0 to 30 inHg)
Engine Speed (0 to 6400 rpm)
Vehicle Speed (0 to 155 mph)

Spark Adv Cyl #1 (0 to 45°)
Intake Air Temp Sensor (0 to 130°F)
Man Air Flow Sensor (0 to 30 lb/min)
Throttle Pos Sensor (0 to 100%)

O2 Sensor B1 S2 (.2 to .8 V) .45 V is ideal
O2 Sensor B2 S2 (.2 to .8 V) .45 V is ideal

Malfunction Indicator Lamp (MIL) ON/OFF

Used XK8 Buyer Advice

After reading and understanding all of the information presented in this article, the following items should be included in your condition inspection. You should also line up a competent Jaguar mechanic to go over the target vehicle prior to any money changing hands.

1. Overall Condition and Mileage. Does the car look as though it has been well cared for? A 10 year old car should have no more than 100K mi to be a good candidate for purchase, unless you have the wherewithal to do the lion's share of the repairs.
2. Service History and Seller Evaluation. Don't buy used Jaguars from dorks. Look for parts receipts and labor invoices or personal seller mechanical ability. If possible speak to whoever maintained the car. Do a reality check on any claims made.
3. Cooling Systems. Look at the fans, radiator fins and hoses for good condition and proper operation. Check coolant color (red/orange) and level. Try to start the car cold and observe what is coming out of the exhaust pipes during initial start and warm-up. It should crank and start readily. Does the engine come up to temperature in five minutes in the middle of gauge range and stay there? Do the fans cycle appropriately from OFF, to Series and then to Parallel (turn on the AC)?
4. Engine Condition, Fluid Leaks and Noises. Look for all conditions that would indicate neglected or incomplete maintenance. If you can, remove the plug covers and disconnect each coil in turn for a few seconds. Any unusual behavior is cause for concern. Listen for unusual tappet or primary chain noises. Check oil level and condition.
5. Engine Bay. Look for cleanliness and attention to detail. Are all fittings and parts OEM equivalents? Check brake and power steering fluid condition. Look for proper engine mount condition with a quick stab at the throttle.
6. Drivetrain. Look for Guibo condition and leaking seals.
7. Suspension. Bounce on each of the wings and observe compression and rebound authority.
8. Steering and Brakes. Look for centering tendency, absence of slop and good braking authority. Look under car in the area of the brakes to ensure that there are no caliper leaks. If you can get each wheel up in turn, check bearings and observe smooth rotation.
9. Wheels and Tires. Visually evaluate tire type and tread, check for curb rash and condition.

10. Electrical and Lighting. Make sure all systems operate to spec in the day and in the dark. With the engine running, check charging voltage at battery B+ (it should be about 14VDC at idle and greater than 12VDC with engine OFF).
11. Entertainment Center and Instruments. Make sure all items operate to spec and radio antenna extends, retracts and stops. Operate all panel buttons and steering stalk functions both sides.
12. Soft Top. Cycle the soft top and observe action. The pump should not sound labored and the top should close or open in less than 20 seconds. Check for proper window sequencing. Check headliner condition and ensure that the soft top cover is available.
13. Interior and Seats. Inspect for leather condition, seat and steering column movement/position memory, lumbar inflation function and ensure that head rests drop as seats are drawn forward and restore upon return.
14. Body, Paint and Corrosion. Operate all doors, boot and bonnet and all locks both manual and remotely operated via the key fob. Look for nicks and overall finish condition. Look under car in the area of the wheel hubs to ensure that there are no caliper leaks and that they are rust free. Inspect the welded body joint at the sills both sides.
15. Glazing. All windshields will have some degree of pitting but ensure that the rest of the glazing is in good condition. Check for window drop as each door is opened and rise as it is closed. Ensure windows roll all the way up, all the way down and the rear window heater is functional.
16. Plastic and Rubber. Look at all plastic and rubber items in the engine bay and under the car to look for cracks.
17. Missing Items. Ensure that there are two covers for the engine firewall corner systems and that the alternator cooling scoop is in place under the car. Ensure passenger side wiper arm pivot cap is not missing. Ensure there are two sets of driver keys and a single valet key.
18. Smog Reports. Review for trends. Check the miles per gallon on the dash computer.
19. OBD2 Scan. Drive the car somewhere and shut it down for a few minutes. Start it up and drive back. It may take multiple events before the OBD2 system logs a code. Look at current real time readings at speed. Look particularly at coolant temperature, fuel trims, lambda sensor readings and catalyst condition.
20. Test Drive. The engine should idle smoothly and take throttle readily. Low end torque should be apparent and the steering should be neutral and not twitchy. At low speed, the suspension should be stiff and at freeway speeds (and up) the car should be well under control regardless of road conditions. There should be only slight lean in corners. Shift into manual (J gate) under a variety of conditions and observe the results. There should be smooth shifting with no back-firing or popping under any conditions. Engage and disengage cruise control functions. Look at all the gauge readings.